

Highly purified media

Complete solutions for process plant

GEA Diessel specializes in planning, construction and qualification of sterile process plant for liquids in pharmaceutical and biotechnology industry. Our process systems are operational within the area of parenterals, fermentation, feed media, blood plasma and special liquids as well as clean utilities.

GEA Diessel has 80 years of expertise and know-how in plant and equipment technology and holds a decisive position in development of modern process technology today.

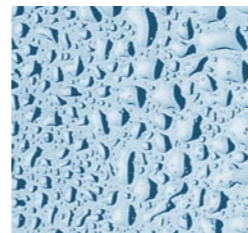

2562.08 Product folder highly purified media / Subject to technical alterations / inform-werbeagentur.de

Highly purified media

Complete solutions for process plant



Water – the basic element in all processes

Water is an important raw material for the production of pharmaceutical liquids, where quality is a prime concern, and an essential ancillary medium for a variety of subordinate processes in the pharmaceutical industry and biotechnology.

In order to be able to produce the requisite quantities of water in the quality laid down in USP and Ph Eur, water plant has to meet very exacting demands. A large number of national and international regulations and standards have to be complied with. Water apparatus is subject to very stringent control and inspection. GEA Diessel plant can fulfill these requirements.



Clean steam generator

Plants for every requirement

Depending on your requirements, we deliver hot or cold storage systems for pure media. The disinfection method is adapted individually to the task. Flow velocity and pressure drop of each loop system are designed in accordance with the cGMP guidelines. Measuring and control instruments required for the monitoring of the water quality (TOC, conductivity, temperature) and of the flow rate belong to our standard. The aseptic design and the qualification of our plant consider the ISPE guidelines for water and steam systems and fulfil particularly the FDA requirements.



Highly purified water – Storage and distribution

The way of water

PW (purified water)
HPW (highly purified water)

- sand and activated carbon filters
- water softening equipment
- reverse osmosis
- continued electrical dionisation
- ultrafiltration
- disinfection (ultraviolet disinfection, ozonisation, sanitisation, sterilisation)
- monitoring of water quality (conductivity, TOC content, temperature)
- storage and distribution

Uses of water in pharmaceuticals and biotechnology:

- for the manufacture of liquid pharmaceuticals
- for media preparation
- for the manufacture of pure pyrogen-free steam for the sterilisation of plant components
- for CIP processes
- for buffer solution preparation

WFI (water for injection)

- distillation
- disinfection
- monitoring of water quality (conductivity, TOC content, temperature)
- storage and distribution

production of highly purified steam

- sterilisation with pure steam

CIP process

Process

- syrup and suspensions
- parenterals
- blood fractionation
- special liquids
- media preparation

Solutions made to measure

GEA Diessel is your competent partner for the integration of highly purified media production plant and for the realisation of the storage and distribution systems. Our experienced process engineers will join with you in developing suitable concepts.

GEA Diessel offers you:

- consultancy
- engineering
- automation
- manufacture of storage vessels
- skids/units
- installation
- qualification
- assistance with validation
- after-sales service



Distillation

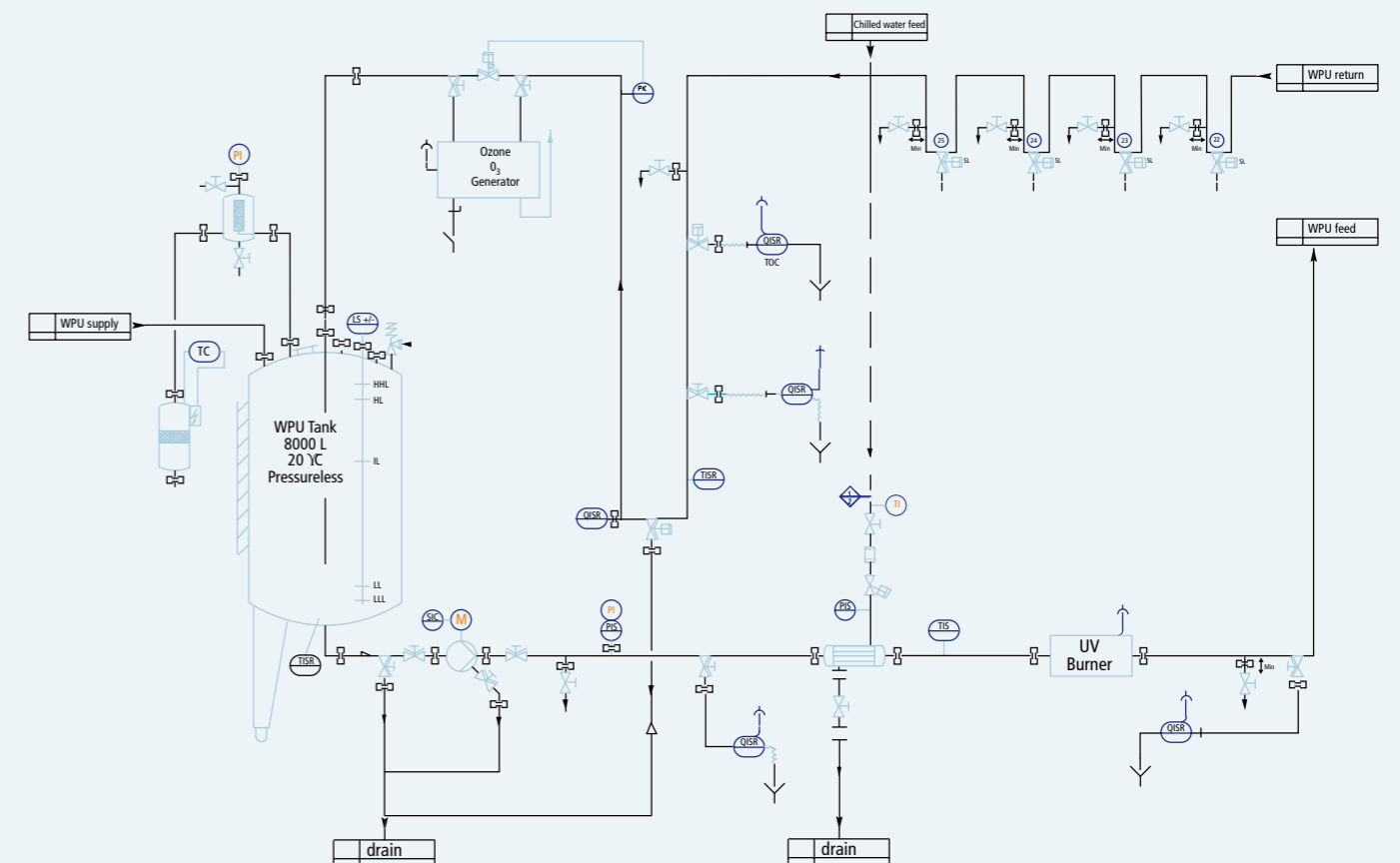

Essential characteristics:

- design free of dead-leg areas
- systems that can be completely evacuated and sterilised
- TOC metering technology
- diaphragm valve technology
- tubular heat exchangers in DTS design
- sampling systems
- sterile filter systems
- constant flow conditions

Automation

We will supply the plant with whatever type of operating system you require: starting from manual operation by buttons and switches, and passing through control systems with operator control units or process visualisation, we can go all the way to instrumentation and control systems capable of controlling several workstations. Records can be kept of process-relevant data.

Loop circulation pump

